

FMS Web Guiding / Steering Frames

FMS-webMASTER BKS 015 Web Guide

- **Sophisticated design:**
Cost effective web guiding solution
- **Integrated electronic unit:**
No additional wiring required
- **No programming required:**
Easy to setup, straightforward use
- **Compact and robust construction:**
Reliable and maintenance free operation



FMS-webMASTER BKS 015

With any type of narrow material processing, it is vital to maintain the web in the correct lateral position. Whether printing labels, gluing pack-ages, laminating layers, or applying isolation layers to a wire, exact material position is most important to the production process. Often this is done with stationary mechanical „guides“ which can damage the material edges. The ultra-compact web guide BKS 015 provides enhanced material control for increased line speeds and improved quality. The innovative, cost-conscious design provides the ideal solution for both existing and new narrow web production lines.

Functional Description

Guiding control modes include Edge Left, Edge Right, and Center Guiding (using two sensors). The powerful stepper motor and ball screw spindle offers both high precision and a fast, accurate response. The electronic control unit is integrated into the steering frame, while the operator interface panel can be provided on either side of the frame and oriented in any of 90° increments to best suit the application. These features make the BKS 015 Web Guide very easy to install and operate. The BKS 015 Web Guide is available with roller widths of 100 to 350 mm, and is compatible with the full line of ultra-sonic and optical material sensors available from FMS.

FMS-webMASTER BKS 015 | Dimensions in mm or [inch]

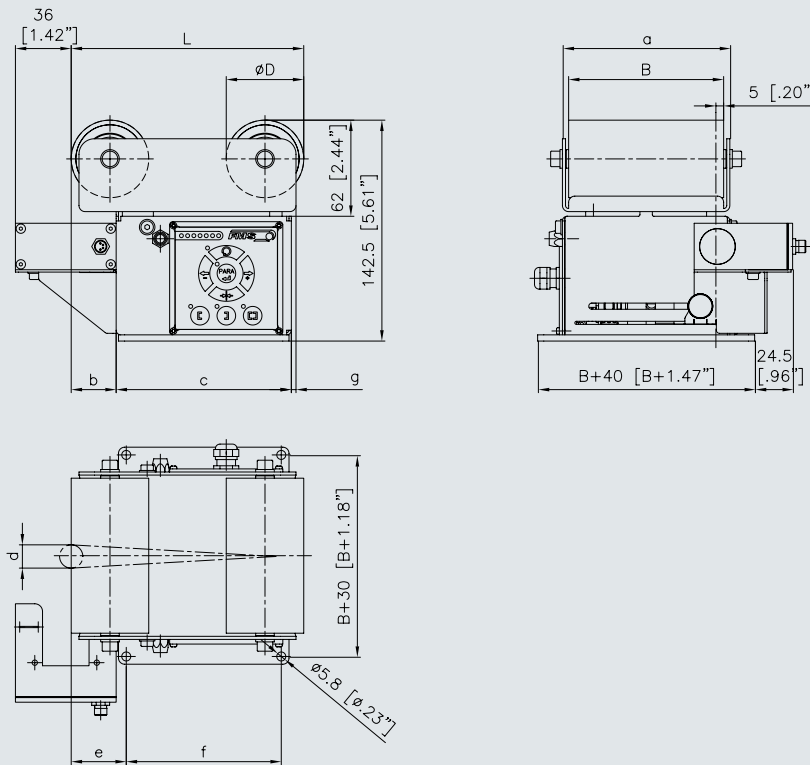

FMS-webMASTER BKS 015 | Dimensions in mm

Web Guide Type	Roller width B	Frame length L	Roller diameter D	a	b	c	d	e	f	g
BKS 015.100.155.50.D	100	155	50	108	34	113	15	40.5	100	3
BKS 015.200.155.50.D	200	155	50	209	34	113	15	40.5	100	8
BKS 015.250.180.50.D	250	180	50	259	34	138	18	40.5	125	8
BKS 015.350.250.75.D	350	250	75	359	34	203	25	40.5	190	8

FMS-webMASTER BKS 015 | Technical Specification

Steering offset	± 7.5 or 9 mm (for B = 250 mm)
Adjusting speed	18 mm/s
Drive	Stepper motor, spindle, backlash free nut
Sensors	Ultrasonic and optical
Power supply	24 VDC (18...30 V) / max. 1.5 A Galvanically isolated
Temperature range	- 10...60 °C [14...140 °F]
Protection class	IP 30

FMS-webMASTER BKS 015 | Texture of the order code

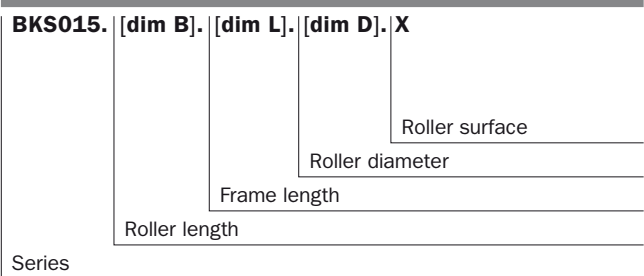

Order code example: BKS015.200.155.50.D