

HOG 10 + FSL

Encoder with integrated centrifugal switch

Blind hollow shaft or cone shaft / 300...5000 pulses per revolution

Overview

- TTL output driver for cable length up to 550 m
- Mechanical speed monitoring based on centrifugal force
- Hybrid bearing for extended service life
- Terminal boxes, turn by 180°



Technical data

Technical data - electrical ratings

Shaft insulation	Suitable up to 2.8 kV
Transmission length	≤350 m at 100 kHz (HTL-P) ≤550 m at 100 kHz (TTL)
Interference immunity	EN 61000-6-2
Emitted interference	EN 61000-6-3
Approval	CE

Technical data - electrical ratings (encoder)

Voltage supply	9...30 VDC; 5 VDC ±5 %
Consumption w/o load	≤100 mA
Pulses per revolution	300 ... 5000
Phase shift	90 ° ±20°
Duty cycle	40...60 %
Reference signal	Zero pulse, width 90°
Output frequency	≤120 kHz ≤300 kHz (on request)
Output signals	K1, K2, K0 + inverted Error output (option EMS)
Output stages	HTL-P (power linedriver) TTL/RS422
Sensing method	Optical

Technical data - electrical ratings (centrifugal switch)

Switching accuracy	± 4 % (Δn = 2 rpm/s); 20 % (Δn = 1500 rpm/s)
Switching deviation	≤3 % (cw-ccw rotation)
Switching hysteresis	40 % of switching speed
Switching outputs	1 output, speed control
Output switching capacity	≤6 A / 230 VAC; ≤1 A / 125 VDC (EAC: <50 VAC / 75 VDC)

Technical data - electrical ratings (centrifugal switch)

Minimum switching current	50 mA
---------------------------	-------

Technical data - mechanical design

Size (flange)	ø105 mm
Shaft type	ø16...20 mm (blind hollow shaft) ø17 mm (cone shaft 1:10)
Admitted shaft load	≤450 N axial ≤600 N radial
Protection EN 60529	IP 66
Speed (n)	≤1.25 · ns
Range of switching speed (ns)	850...4500 rpm (Δn = 2 rpm/s)
Operating torque typ.	6 Ncm
Rotor moment of inertia	400 gcm ²
Material	Housing: aluminium die-cast Shaft: stainless steel
Operating temperature	-40...+100 °C -25...+100 °C (>3072 pulses) -50...+100 °C (optional)
Resistance	IEC 60068-2-6 Vibration 5 g, 10-2000 Hz IEC 60068-2-27 Shock 50 g, 11 ms
Corrosion protection	IEC 60068-2-52 Salt mist for ambient conditions C4 according to ISO 12944-2
Connection	2x terminal box 3x terminal box (with option M)
Weight approx.	2.2 kg 2.4 kg (with option M)

HOG 10 + FSL

Encoder with integrated centrifugal switch

Blind hollow shaft or cone shaft / 300...5000 pulses per revolution

Optional

- Function control with EMS (Enhanced Monitoring System)
- Redundant sensing with two terminal boxes
- With heating up to -50°C

HOG 10 + FSL

Encoder with integrated centrifugal switch

Blind hollow shaft or cone shaft / 300...5000 pulses per revolution

General information

The constructive design of the centrifugal switch is its use as a switch with positive break function. It must not be used as a continuous switch (switching cycles greater than 500 during service life).

Terminal assignment

View A (see dimension)

Connecting terminal terminal box encoder

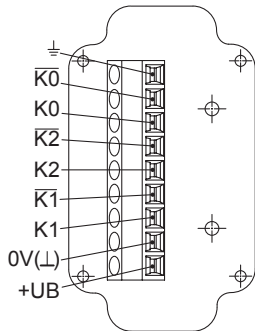

Option EMS: View A (see dimension)

Connecting terminal terminal box encoder

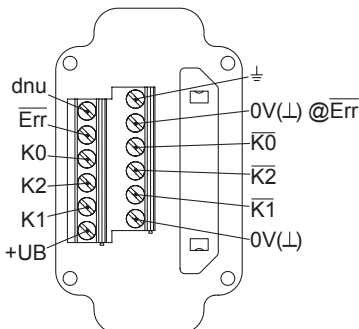

View B (see dimension)

Connecting terminal centrifugal switch

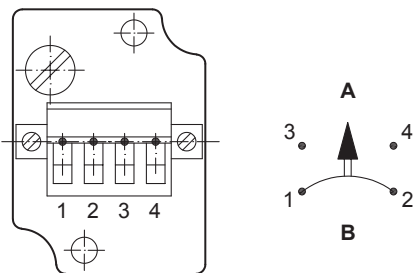

A = make contact, B = break contact

Terminal significance

Encoder incremental

+UB	Voltage supply
0V (L)	Ground
⊥	Earth ground (housing)
K1	Output signal channel 1
$\overline{K1}$	Output signal channel 1 inverted
K2	Output signal channel 2 (offset by 90° to channel 1)
$\overline{K2}$	Output signal channel 2 inverted
K0	Zero pulse (reference signal)
$\overline{K0}$	Zero pulse inverted
\overline{Err}	Error output (option EMS)
dnu	Do not use

Output signals

HTL/TTL

At positive rotating direction (see dimension)

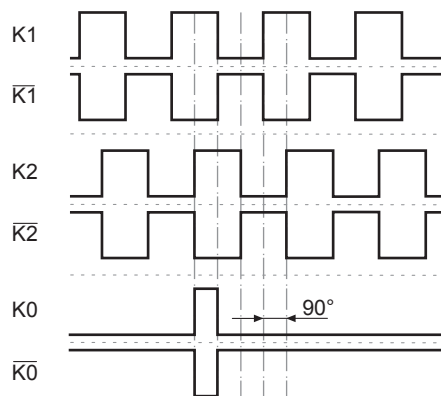

Option EMS: Status LED / error output

Flash light red*	Error of signal sequence, zero pulse or pulses (Error output = HIGH-LOW alternation)
Red	Overload output transistors (Error output = LOW)
Flash light green	Device o.k., rotating (Error output = HIGH)
Green	Device o.k., stopped (Error output = HIGH)
No light	No voltage supply connection or wrong connection (Error output = LOW)

* Only at rotating device

HOG 10 + FSL

Encoder with integrated centrifugal switch

Blind hollow shaft or cone shaft / 300...5000 pulses per revolution

Dimensions

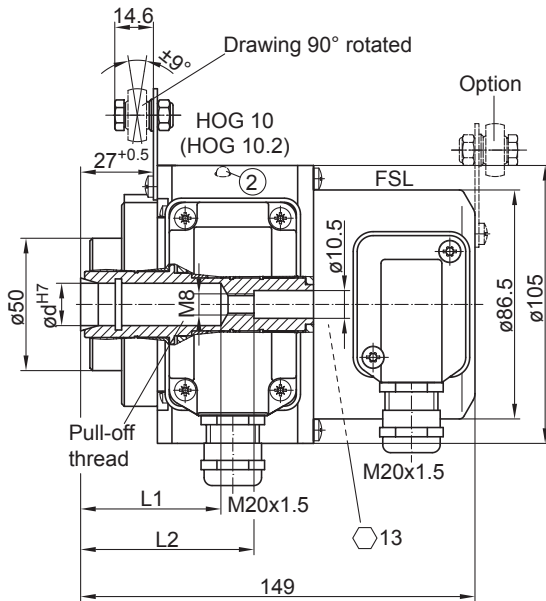

ød	L1	L2
16	53	65.5
20	35	51.5

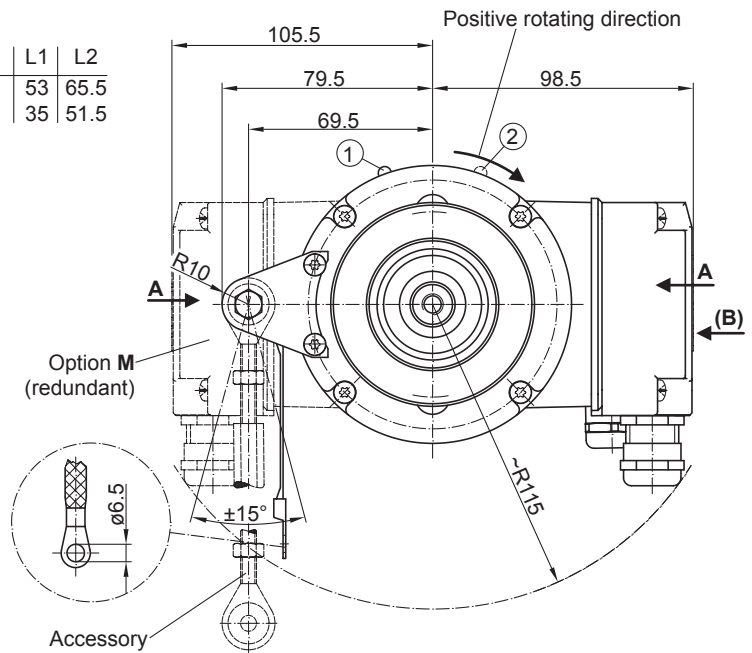

- ① Status LED (option EMS)
- ② Status LED (option **M** (redundant) and EMS)

Blind hollow shaft

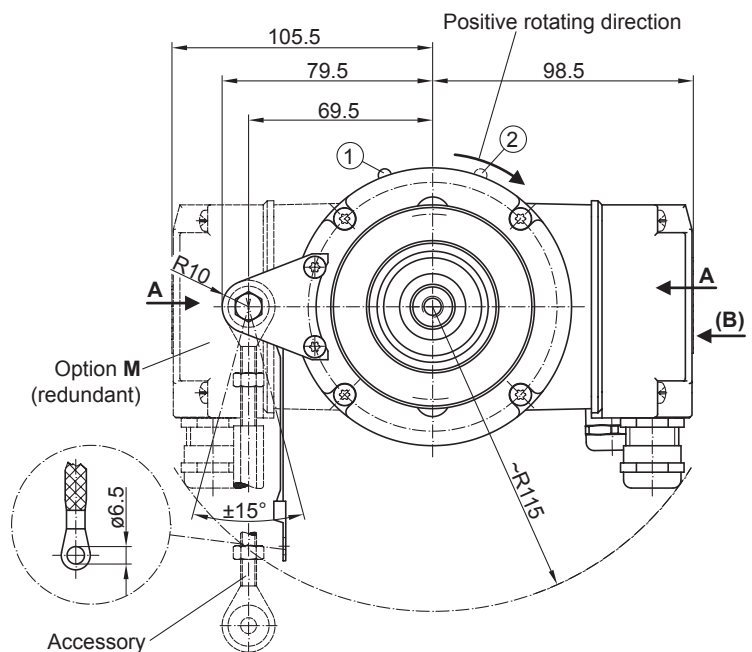
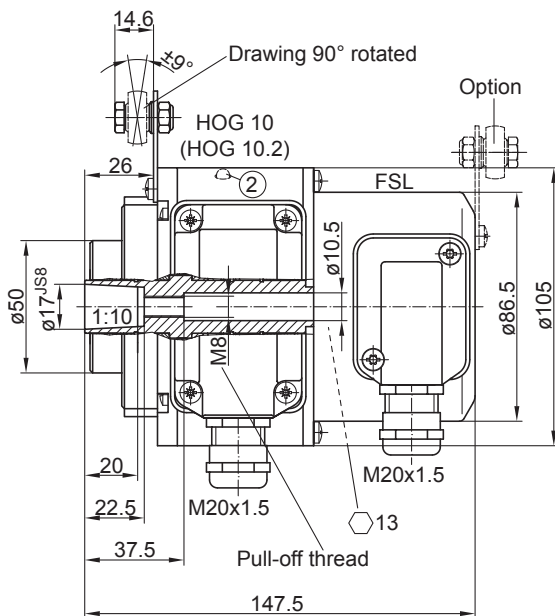

- ① Status LED (option EMS)
- ② Status LED (option **M** (redundant) and EMS)

Cone shaft

HOG 10 + FSL

Encoder with integrated centrifugal switch

Blind hollow shaft or cone shaft / 300...5000 pulses per revolution

Ordering reference

	HOG10	##	#	DN	####	###	##	#####	+ FSL	#####
Product										
Incremental encoder + Centrifugal switch	HOG10									
EMS - Enhanced Monitoring System										
Without EMS										
With EMS		.2								
Redundant sensing										
Without redundant sensing										
With redundant sensing			M							
Output signals										
K1, K2, K0				DN						
Pulse number⁽¹⁾										
300					300					
500					500					
512					512					
1000					1000					
1024					1024					
1200					1200					
2048					2048					
2500					2500					
3072					3072					
4096					4096					
5000					5000					
Voltage supply / output stage										
9...30 VDC / output stage HTL with inverted signals						I				
5 VDC / output stage TTL with inverted signals							TTL			
9...30 VDC / output stage TTL with inverted signals								R		
Sealing system										
Dust protection								LR		
Damp protection									SR	
Shaft diameter										
Blind hollow shaft ø16 mm									16H7	
Blind hollow shaft ø20 mm										20H7
Cone shaft ø17 mm (1:10)										17K
Version speed switch										
Mechanical centrifugal switch									+ FSL	
Switching speed (ns)										
850...949 rpm ($\Delta n = 2$ rpm/s) ⁽²⁾										6 ...
950...1099 rpm ($\Delta n = 2$ rpm/s) ⁽²⁾										5 ...
1100...1299 rpm ($\Delta n = 2$ rpm/s) ⁽²⁾										4 ...
1300...1799 rpm ($\Delta n = 2$ rpm/s) ⁽²⁾										3 ...
1800...2499 rpm ($\Delta n = 2$ rpm/s) ⁽²⁾										2 ...
2500...4500 rpm ($\Delta n = 2$ rpm/s) ⁽²⁾										1 ...

(1) Other pulse numbers on request.

(2) Please specify the exact switching speed in addition to the part number (factory setting).

HOG 10 + FSL

Encoder with integrated centrifugal switch

Blind hollow shaft or cone shaft / 300...5000 pulses per revolution

Accessories

Mounting accessories

11077197	Mounting kit for torque arm size M6 and earthing strap
11077087	Mounting and dismantling set
11043628	Torque arm M6, length 67...70 mm
11004078	Torque arm M6, length 120...130 mm (≥ 71 mm)
11002915	Torque arm M6, length 425...460 mm (≥ 131 mm)
11054917	Torque arm M6 insulated, length 67...70 mm
11072795	Torque arm M6 insulated, length 120...130 mm (≥ 71 mm)
11082677	Torque arm M6 insulated, length 425...460 mm (≥ 131 mm)