

POG 10 + FSL

Encoder with integrated centrifugal switch

Solid shaft with EURO flange B10 / 300...5000 pulses per revolution

Overview

- TTL output driver for cable length up to 550 m
- Mechanical speed monitoring based on centrifugal force
- EURO flange B10 / solid shaft $\varnothing 11$ mm
- Terminal boxes, turn by 180°



Technical data

Technical data - electrical ratings

Interference immunity	EN 61000-6-2
Emitted interference	EN 61000-6-3
Approval	CE

Technical data - electrical ratings (encoder)

Voltage supply	9...30 VDC 5 VDC ± 5 %
Consumption w/o load	≤ 100 mA
Pulses per revolution	300 ... 5000
Phase shift	$90^\circ \pm 20^\circ$
Duty cycle	40...60 %
Reference signal	Zero pulse, width 90°
Output frequency	≤ 120 kHz ≤ 300 kHz (on request)
Output signals	K1, K2, K0 + inverted Error output (option EMS)
Output stages	HTL-P (power linedriver) TTL/RS422
Sensing method	Optical

Technical data - electrical ratings (centrifugal switch)

Switching accuracy	± 4 % ($\Delta n = 2$ rpm/s); 20 % ($\Delta n = 1500$ rpm/s)
Switching deviation	≤ 3 % (cw-ccw rotation)
Switching hysteresis	40 % of switching speed
Switching outputs	1 output, speed control
Output switching capacity	≤ 6 A / 230 VAC ≤ 1 A / 125 VDC (EAC: ≤ 50 VAC / 75 VDC)

Technical data - electrical ratings (centrifugal switch)

Minimum switching current	50 mA
---------------------------	-------

Technical data - mechanical design

Size (flange)	$\varnothing 115$ mm
Shaft type	$\varnothing 11$ mm solid shaft
Admitted shaft load	≤ 300 N axial ≤ 450 N radial
Flange	EURO flange B10
Protection EN 60529	IP 66
Speed (n)	$\leq 1.25 \cdot ns$
Range of switching speed (ns)	850...4500 rpm ($\Delta n = 2$ rpm/s)
Operating torque typ.	3 Ncm
Rotor moment of inertia	220 gcm ²
Material	Housing: aluminium die-cast Shaft: stainless steel
Operating temperature	-40...+100 °C -25...+100 °C (>3072 pulses) -50...+100 °C (optional)
Resistance	IEC 60068-2-6 Vibration 10 g, 10-2000 Hz IEC 60068-2-27 Shock 100 g, 6 ms
Corrosion protection	IEC 60068-2-52 Salt mist for ambient conditions C4 according to ISO 12944-2
Connection	2x terminal box 3x terminal box (with option M)
Weight approx.	2.3 kg 2.5 kg (with option M)

POG 10 + FSL

Encoder with integrated centrifugal switch

Solid shaft with EURO flange B10 / 300...5000 pulses per revolution

Optional

- Function control with EMS (Enhanced Monitoring System)
- Redundant sensing with two terminal boxes
- Housing foot (B3)
- With heating up to -50°C

POG 10 + FSL

Encoder with integrated centrifugal switch

Solid shaft with EURO flange B10 / 300...5000 pulses per revolution

General information

The constructive design of the centrifugal switch is its use as a switch with positive break function. It must not be used as a continuous switch (switching cycles greater than 500 during service life).

Terminal assignment

View A (see dimension)

Connecting terminal terminal box encoder

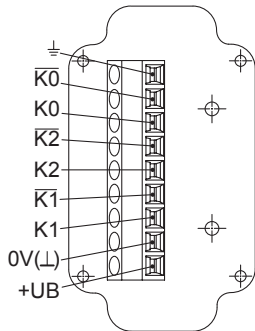

Option EMS: View A (see dimension)

Connecting terminal terminal box encoder

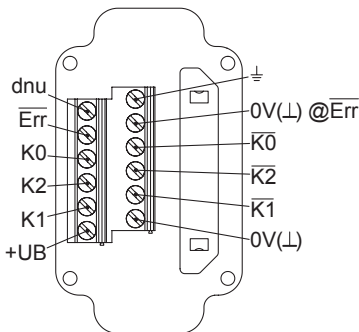

View B (see dimension)

Connecting terminal centrifugal switch

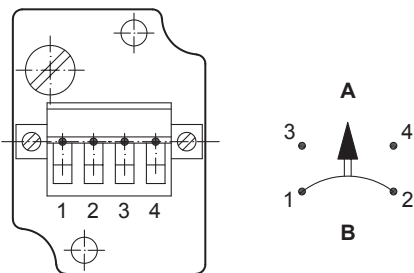

A = make contact, B = break contact

Terminal significance

Encoder incremental

+UB	Voltage supply
0V (L)	Ground
⊥	Earth ground (housing)
K1	Output signal channel 1
$\overline{K1}$	Output signal channel 1 inverted
K2	Output signal channel 2 (offset by 90° to channel 1)
$\overline{K2}$	Output signal channel 2 inverted
K0	Zero pulse (reference signal)
$\overline{K0}$	Zero pulse inverted
\overline{Err}	Error output (option EMS)
dnu	Do not use

Output signals

HTL/TTL

At positive rotating direction (see dimension)

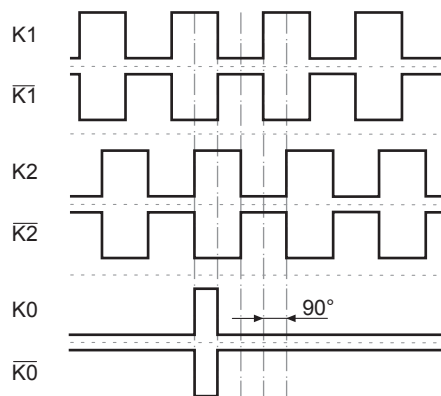

Option EMS: Status LED / error output

Flash light red*	Error of signal sequence, zero pulse or pulses (Error output = HIGH-LOW alternation)
Red	Overload output transistors (Error output = LOW)
Flash light green	Device o.k., rotating (Error output = HIGH)
Green	Device o.k., stopped (Error output = HIGH)
No light	No voltage supply connection or wrong connection (Error output = LOW)

* Only at rotating device

POG 10 + FSL

Encoder with integrated centrifugal switch

Solid shaft with EURO flange B10 / 300...5000 pulses per revolution

Dimensions

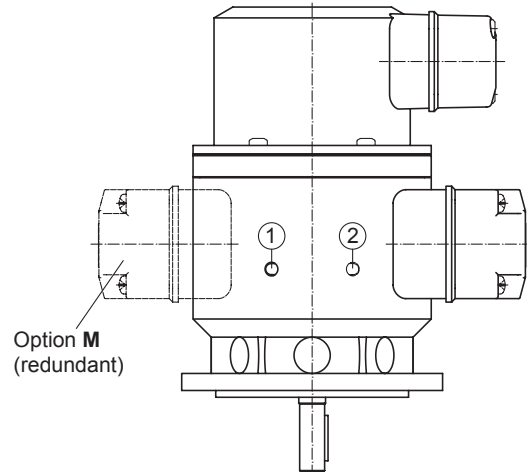
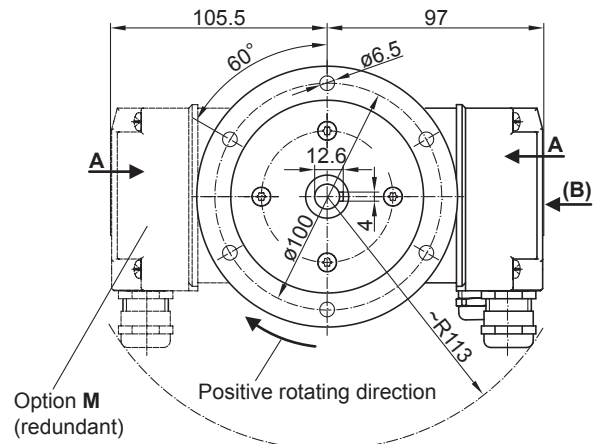
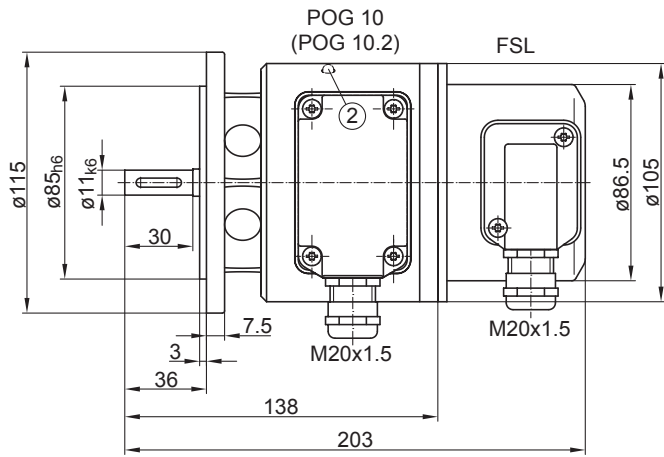

- ① Status LED (option EMS)
- ② Status LED (option M (redundant) and EMS)

EURO flange B10

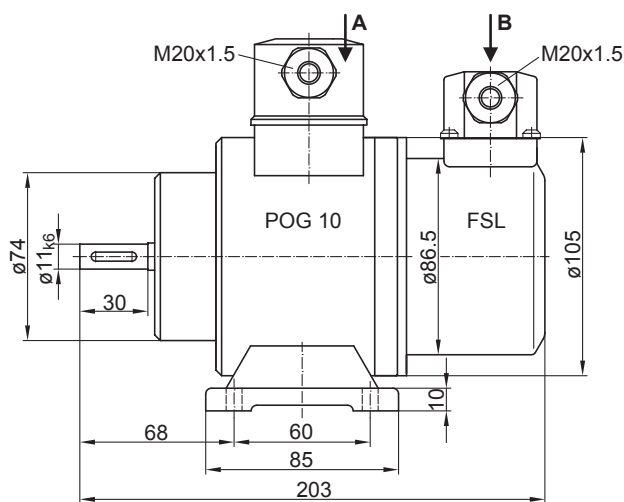

Housing foot B3

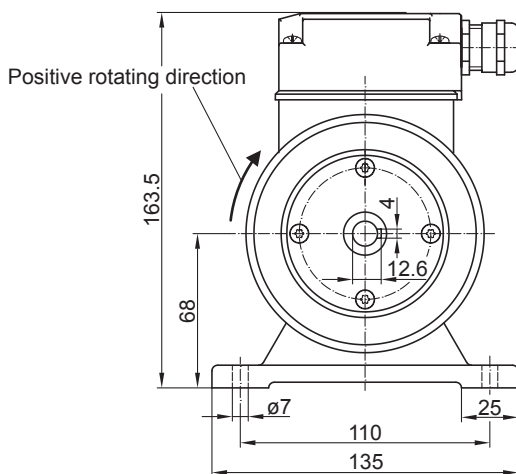

POG 10 + FSL

Encoder with integrated centrifugal switch

Solid shaft with EURO flange B10 / 300...5000 pulses per revolution

Ordering reference

	POG10	##	#	DN	####	###	#####	+ FSL	#####
Product									
Incremental encoder + Centrifugal switch	POG10								
EMS - Enhanced Monitoring System									
Without EMS									
With EMS		.2							
Redundant sensing									
Without redundant sensing									
With redundant sensing			M						
Output signals									
K1, K2, K0				DN					
Pulse number⁽¹⁾									
300					300				
500					500				
512					512				
1000					1000				
1024					1024				
1200					1200				
2048					2048				
2500					2500				
3072					3072				
4096					4096				
5000					5000				
Voltage supply / output stage									
9...30 VDC / output stage HTL with inverted signals						I			
5 VDC / output stage TTL with inverted signals						TTL			
9...30 VDC / output stage TTL with inverted signals						R			
Mounting type									
EURO flange B10									
Housing foot B3							B3		
Version speed switch									
Mechanical centrifugal switch								+ FSL	
Switching speed (ns)									
850...949 rpm ($\Delta n = 2$ rpm/s) ⁽²⁾									6 ...
950...1099 rpm ($\Delta n = 2$ rpm/s) ⁽²⁾									5 ...
1100...1299 rpm ($\Delta n = 2$ rpm/s) ⁽²⁾									4 ...
1300...1799 rpm ($\Delta n = 2$ rpm/s) ⁽²⁾									3 ...
1800...2499 rpm ($\Delta n = 2$ rpm/s) ⁽²⁾									2 ...
2500...4500 rpm ($\Delta n = 2$ rpm/s) ⁽²⁾									1 ...

(1) Other pulse numbers on request.

(2) Please specify the exact switching speed in addition to the part number (factory setting).

Accessories

Mounting accessories

- Spring disk coupling K 35 (shaft $\varnothing 6...12$ mm)
- Spring disk coupling K 50 (shaft $\varnothing 11...16$ mm)
- Spring disk coupling K 60 (shaft $\varnothing 11...22$ mm)