

Tachogenerators

Blind hollow shaft $\varnothing 16$ mm

Housing $\varnothing 95$ mm, bearingless configuration

GTR 9



GTR 9

Features

- Low response time
- Open circuit voltage 20...60 mV per rpm
- Blind hollow shaft $\varnothing 16$ mm
- High signal quality due to patented LongLife technology
- Connector output
- No auxiliary energy source required

Technical data - electrical ratings

Reversal tolerance	≤ 0.1 %
Linearity tolerance	≤ 0.15 %
Temperature coefficient	± 0.05 %/K (open-circuit), optional: 0.005 %/K
Isolation class	B
Calibration tolerance	± 5 %
Climatic test	Humid heat, constant (IEC 60068-2-3, Ca)
Performance	0.9 W (speed ≥ 5000 rpm)
Armature-circuit time-constant	< 5 μ s
Open-circuit voltage	20...60 mV per rpm
Interference immunity	EN 61000-6-2
Emitted interference	EN 61000-6-3
Approval	CE

Technical data - mechanical design

Size (flange)	$\varnothing 95$ mm
Shaft type	$\varnothing 16$ mm (blind hollow shaft)
Protection DIN EN 60529	IP 56
Torque	0.35 Ncm
Rotor moment of inertia	1.95 kgcm ²
Materials	Housing: stainless steel / plastic Shaft: stainless steel
Operating temperature	-30...+130 °C
Resistance	IEC 60068-2-6 Vibration 10 g, 10-2000 Hz IEC 60068-2-27 Shock 100 g, 6 ms
Weight approx.	1.1 kg
Connection	Connector

Tachogenerators

Blind hollow shaft $\varnothing 16$ mm
Housing $\varnothing 95$ mm, bearingless configuration

GTR 9

Part number

GTR9.16L/4

	Open-circuit voltage
20	20 mV per rpm
30	30 mV per rpm
40	40 mV per rpm
60	60 mV per rpm

Data according to type

Type	Off-load voltage U_0 [mV/rpm]	Minimum load required depending on speed range [rpm]			Maximum operating speed n_{max} [rpm]	Armature resistance $R_A(20^\circ C)$ [Ω]	Armature inductance L_A [mH]
		0-3000	0-6000	0- n_{max}			
GTR9.16L/420	20	≥ 7	≥ 16	≥ 36	9000	39	31
GTR9.16L/430	30	≥ 15	≥ 36	≥ 82	9000	84	69
GTR9.16L/440	40	≥ 27	≥ 64	≥ 144	9000	165	122
GTR9.16L/460	60	≥ 60	≥ 144	–	6000	340	275

Superimposed ripple (for $\tau_{RC} = 0.3$ ms): $\leq 0.4\%$ (peak-peak) $\leq 0.15\%$ (rms)

Replacement switching diagram

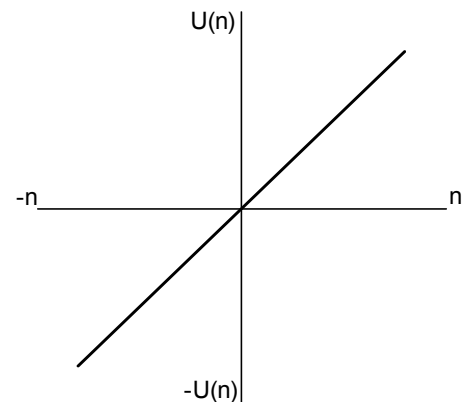
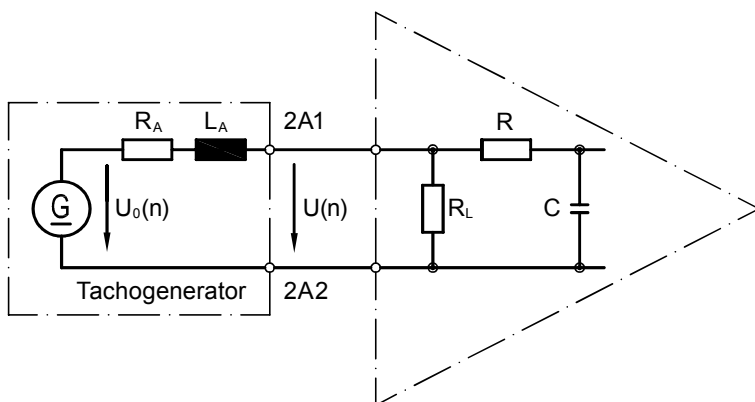

$$\tau_{RC} \approx R \cdot C \quad \tau_A \approx \frac{L_A}{R_L}$$

$$U(n) = U_0(n) \frac{R_L}{R_A + R_L} \approx U_0(n) \text{ for } R > R_L \gg R_A$$

Polarity for positive rotating direction: 2A1: + 2A2: - (VDE)

Tachogenerators

Blind hollow shaft $\varnothing 16$ mm

Housing $\varnothing 95$ mm, bearingless configuration

GTR 9

Terminal assignment

View A - Connecting terminal

Polarity for positive direction of rotation

Accessories

Mounting cone

Carbon brushes

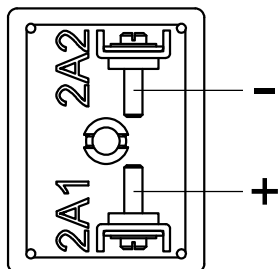

Dimensions

GTR 9.16

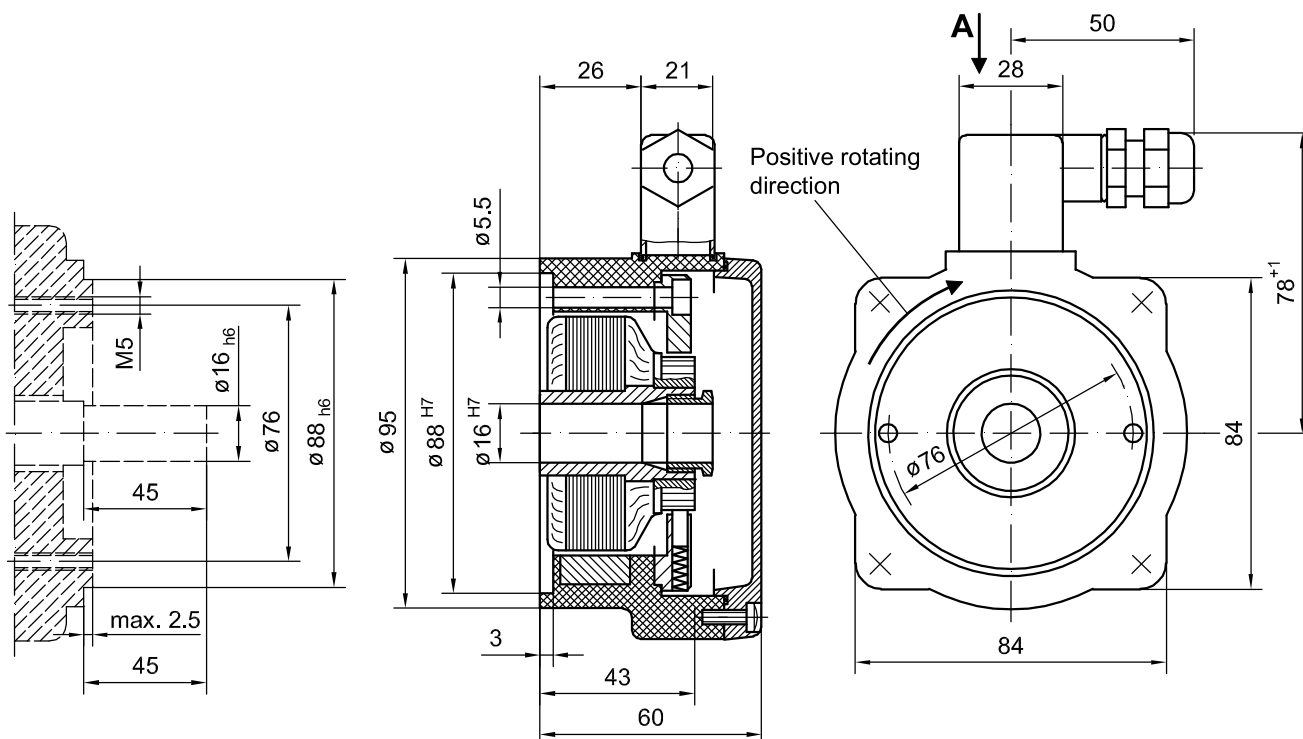

HM87M21438

Tachogenerators

Blind hollow shaft $\varnothing 16$ mm
Housing $\varnothing 95$ mm, bearingless configuration

GTR 9
