

HMG10-T - SSI

Through hollow shaft

ST and MT 20 bit each / Speed switch

Overview

- Magnetic sensing method
- Function display via LEDs
- Multiturn sensing with Energy Harvesting technology "MicroGen", without gear or battery
- Two-sided bearing system with hybrid bearings
- Special protection against corrosion CX (C5-M)



Picture similar



Technical data

Technical data - electrical ratings

Voltage supply	4.75...30 VDC
Short-circuit proof	Yes
Consumption w/o load	≤100 mA (SSI)
Initializing time	≤ 500 ms after power on
Interface	SSI
Function	Multiturn
Steps per revolution	1048576 / 20 bit
Number of revolutions	1048576 / 20 bit
Additional outputs	Square-wave TTL/HTL, TTL/RS422
Sensing method	Magnetic
Code	Gray or binary
Code sequence	CW (factory setting)
Input signals	SSI clock, PRESET, rotating direction
Interference immunity	EN 61000-6-2
Emitted interference	EN 61000-6-3
Diagnostic function	Function control
Status indicator	4 LEDs in device back side
Approval	CE UL approval / E217823 EAC

Technical data - electrical ratings (speed switch)

Switching accuracy	± 2 % (or 1 Digit)
Switching outputs	1 output (Open collector, solid state relay on request)
Output switching capacity	30 VDC; ≤100 mA

Technical data - electrical ratings (speed switch)

Switching delay time	≤20 ms
Technical data - mechanical design	
Size (flange)	ø105 mm
Shaft type	ø16...20 mm (through hollow shaft)
Flange	Support plate, 360° freely positionable
Protection EN 60529	IP 66/IP 67
Operating speed	≤12000 rpm
Range of switching speed	ns (off) = ±2...12000 rpm
Operating torque typ.	10 Ncm
Rotor moment of inertia	950 gcm ²
Admitted shaft load	≤450 N axial ≤650 N radial
Material	Housing: aluminium alloy Shaft: stainless steel
Corrosion protection	IEC 60068-2-52 Salt mist for ambient conditions CX (C5-M) according to ISO 12944-2
Operating temperature	-40...+95 °C
Relative humidity	95 % non-condensing
Resistance	IEC 60068-2-6 Vibration 30 g, 10-2000 Hz IEC 60068-2-27 Shock 400 g, 1 ms
Weight approx.	1.6 kg (depending on version)
Connection	Terminal box Flange connector M23

Optional

- Integrated speed switch
- Additional outputs incremental with zero pulse

HMG10-T - SSI

Through hollow shaft

ST and MT 20 bit each / Speed switch

Terminal assignment

View A (see dimension)

Connecting terminal terminal box

SSI /

additional output I (HTL, TTL)

* Assignment depends on encoder version

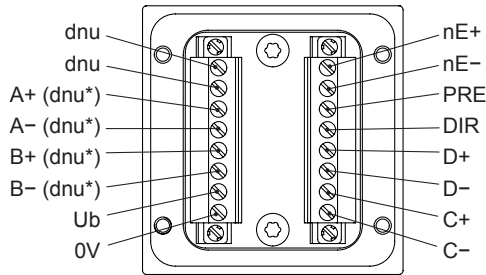

View B (see dimension)

Connecting terminal terminal box

Speed switch /

additional output II (HTL, TTL)

* Assignment depends on encoder version

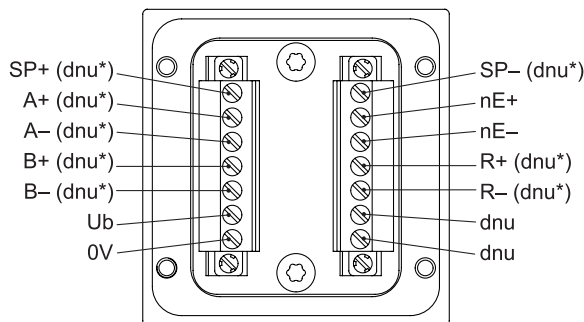

Terminal assignment

View C (see dimension)

Assignment flange connector

SSI / additional output I (HTL, TTL)

* Assignment depends on encoder version

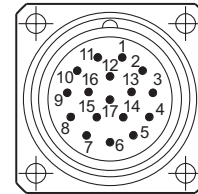

Flange socket M23
(male, 17-pin),
CW

Pin	Assignment
1	nE-
2	DIR
3	dnu
4	nE+
5	PRE
6	dnu
7	Ub
8	C+
9	C-
10	0V
11	Internal shield
12	B+ (dnu*)
13	B- (dnu*)
14	D+
15	A+ (dnu*)
16	A- (dnu*)
17	D-

HMG10-T - SSI

Through hollow shaft

ST and MT 20 bit each / Speed switch

Terminal assignment

View D (see dimension)

Assignment flange connector

Speed switch / additional output II (HTL, TTL)

* Assignment depends on encoder version

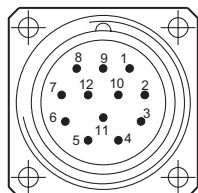

Flange socket M23
(male, 12-pin),
CW

Pin	Assignment
1	B- (dnu*)
2	nE-
3	R+ (dnu*)
4	R- (dnu*)
5	A+ (dnu*)
6	A- (dnu*)
7	SP+ (dnu*)
8	B+ (dnu*)
9	SP- (dnu*)
10	0V
11	nE+
12	Ub

Terminal significance

Ub	Voltage supply
0V	Ground
A+	Output signal channel 1
A-	Output signal channel 1 inverted
B+	Output signal channel 2 (offset by 90° to channel 1)
B-	Output signal channel 2 inverted
R+	Zero pulse (reference signal)
R-	Zero pulse inverted
nE+	System OK+ / error output
nE-	System OK_ / error output inverted
PRE	PRESET/RESET
DIR	Rotating direction
SP+	DSL_OUT1 / speed switch (Open collector, solid state relay on request)
SP-	DSL_OUT2 / speed switch (0V, solid state relay on request)
D+	SSI data+
D-	SSI data-
C+	SSI clock+
C-	SSI clock-
dnu	Do not use

Output signals

Additional output I (HTL/TTL)

At positive rotating direction (see dimension)

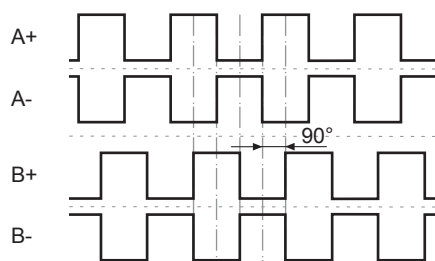

Additional output II (HTL/TTL)

At positive rotating direction (see dimension)

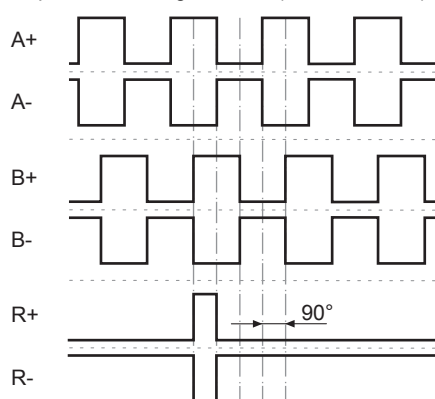

Trigger level

Incremental HTL/TTL

Electrically isolated:

The output TTL/HTL ($V_{in} = V_{out}$) at the additional output II is electrically isolated and requires a separate power supply.

Trigger level	TTL/RS422
High / Low	$\geq 2.5 \text{ V} / \leq 0.5 \text{ V}$
Transmission length	$\leq 550 \text{ m @ } 100 \text{ kHz}$
Output frequency	$\leq 600 \text{ kHz}$
Trigger level	TTL/HTL ($V_{in} = V_{out}$)
High / Low	$\geq 2.5 \text{ V} / \leq 0.5 \text{ V (TTL)}$ $\geq U_b - 3 \text{ V} / \leq 1.5 \text{ V (HTL)}$
Transmission length	$\leq 550 \text{ m @ } 100 \text{ kHz (TTL)}$ $\leq 350 \text{ m @ } 100 \text{ kHz (HTL)}$
Output frequency	$\leq 600 \text{ kHz (TTL); } \leq 350 \text{ kHz (HTL)}$

HMG10-T - SSI

Through hollow shaft

ST and MT 20 bit each / Speed switch

Data transfer

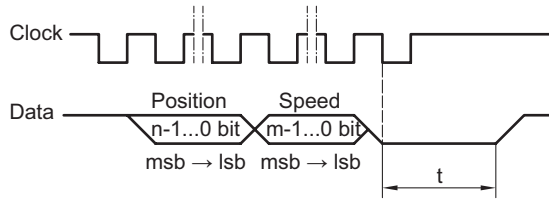

Clock frequency 100 kHz...2 MHz

Monoflop time (t) 20 µs (internal)

n, m Number of bits

For continuous clocking, the SSI word is transmitted only once followed by zero values (no ring register operation).

Switching characteristics speed switch

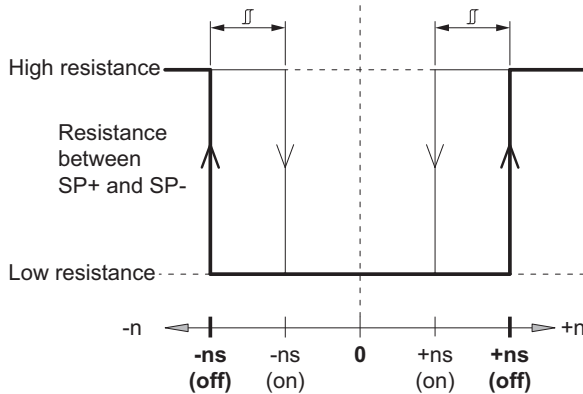

n	Speed
+ns (off)	Switch-off speed at shaft rotation in positive rotating direction (<i>see dimension</i>).
-ns (off)	Switch-off speed at shaft rotation in negative rotating direction (<i>see dimension</i>).
	Switching hysteresis Δ : 10...100 % (factory setting = 10 % min. 1 Digit)
+ns (on)	Switch-on speed at shaft rotation in positive rotating direction (<i>see dimension</i>).
-ns (on)	Switch-on speed at shaft rotation in negative rotating direction (<i>see dimension</i>).

HMG10-T - SSI

Through hollow shaft

ST and MT 20 bit each / Speed switch

Dimensions

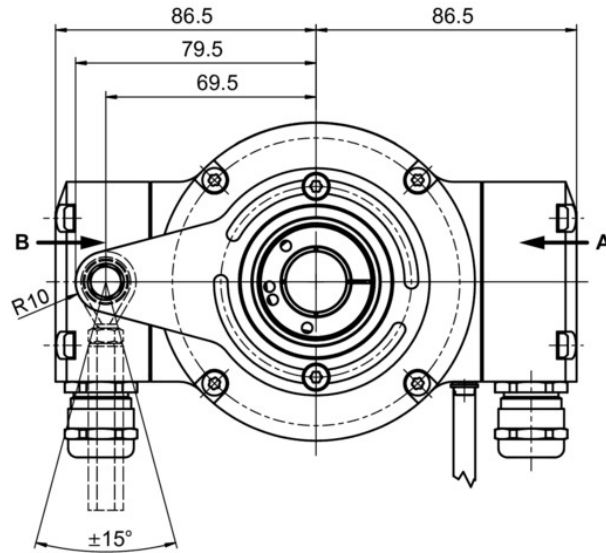
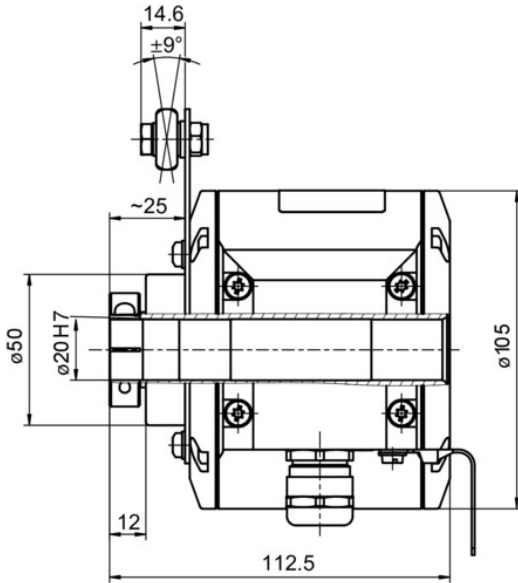

Through hollow shaft with terminal box

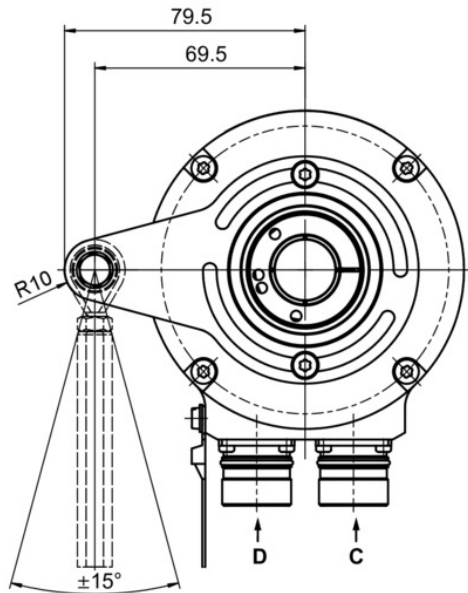
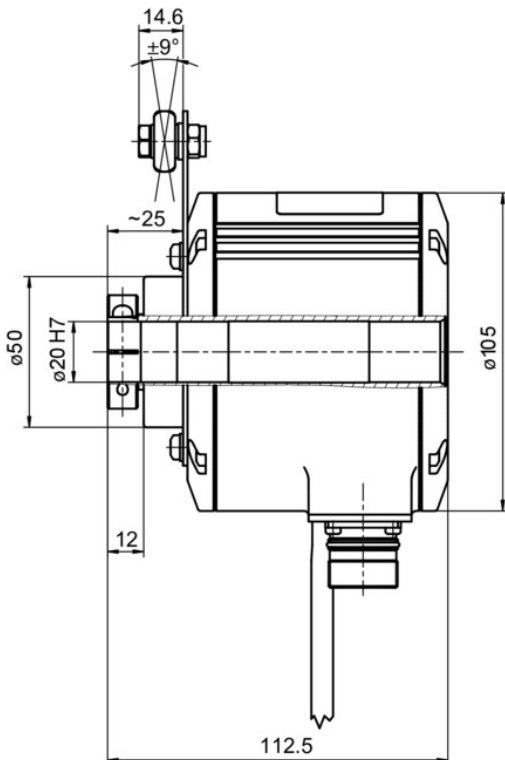

Through hollow shaft with connector M23

HMG10-T - SSI

Through hollow shaft

ST and MT 20 bit each / Speed switch

Ordering reference

	HMG10	#	-	T	H	#	.	#	#	##	.	#	#	#	#	#	.	#	
Product	HMG10																		
Absolute encoder	HMG10																		
Digital speed switch																			
With ⁽¹⁾				D															
Without				-															
Shaft type					T														
Through hollow shaft					T														
Flange (Hollow shaft)						H													
Support (Support plate) for torque arm, hybrid bearings						H													
Protection class																			
IP 66 and IP 67, optimized for dusty, abrasive environment																			D
IP 66 and IP 67, optimized for oily, wet environment																			L
Through hollow shaft																			
Ø16 mm, clamping ring, A end																			C
Ø20 mm, clamping ring, A end																			F
Ø16 mm, keyway																			P
Connection																			
Terminal box radial, cable gland M20																			2
Terminal box 2x radial, cable gland M20																			M
Flange socket radial, M23, 17 pin, male, CW																			G
Flange socket radial, 1x M23, 17 pin, male, CW + 1x M23, 12 pin, male, CW																			S
Flange socket radial, 1x M23, 17 pin, male, CW + 1x M23, 12 pin, male, CCW																			V
Supply voltage																			
4,75...30 VDC, SSI binary																			UB
4,75...30 VDC, SSI Gray																			UG
Resolution singleturn position																			
No position signal																			0
10 Bit																			A
11 Bit																			1
12 Bit																			2
13 Bit																			3
14 Bit																			4
15 Bit																			5
16 Bit																			6
17 Bit																			7
18 Bit																			8
19 Bit																			9
20 Bit																			B

HMG10-T - SSI

Through hollow shaft

ST and MT 20 bit each / Speed switch

Ordering reference
HMG10 # - T H # . # # ## . # # # # # . #
Resolution multiturn position

No multiturn signal	0
10 Bit	A
11 Bit	1
12 Bit	2
13 Bit	3
14 Bit	4
15 Bit	5
16 Bit	6
17 Bit	7
18 Bit	8
19 Bit	9
20 Bit	B

Resolution speed

No speed signal	0
10 Bit, ±6000 rpm	A
11 Bit, ±6000 rpm	1
12 Bit, ±6000 rpm	2
13 Bit, ±6000 rpm	3
14 Bit, ±6000 rpm	4
15 Bit, ±6000 rpm	5
16 Bit, ±6000 rpm	6
17 Bit, ±6000 rpm	7
18 Bit, ±6000 rpm	8
19 Bit, ±6000 rpm	9
20 Bit, ±6000 rpm	B

Resolution supplement I

No additional output I	0
8192 ppr TTL/HTL push-pull (Vin=Vout), 4 channels	Q
8192 ppr TTL (RS422), 4 channels	P
5000 ppr TTL/HTL push-pull (Vin=Vout), 4 channels	G
5000 ppr TTL (RS422), 4 channels	H
4096 ppr TTL/HTL push-pull (Vin=Vout), 4 channels	K
4096 ppr TTL (RS422), 4 channels	J
3072 ppr TTL/HTL push-pull (Vin=Vout), 4 channels	7
3072 ppr TTL (RS422), 4 channels	8
2048 ppr TTL/HTL push-pull (Vin=Vout), 4 channels	9
2048 ppr TTL (RS422), 4 channels	4
1024 ppr TTL/HTL push-pull (Vin=Vout), 4 channels	5
1024 ppr TTL (RS422), 4 channels	6
512 ppr TTL/HTL push-pull (Vin=Vout), 4 channels	1
512 ppr TTL (RS422), 4 channels	2

HMG10-T - SSI

Through hollow shaft

ST and MT 20 bit each / Speed switch

Ordering reference

	HMG10	#	-	T	H	#	.	#	#	##	.	#	#	#	#	#	.	#	
Resolution supplement II																			
No additional output II																			0
8192 ppr TTL/HTL push-pull (Vin=Vout), 6 channels, electrically isolated																			Q
8192 ppr TTL (RS422), 6 channels																			P
5000 ppr TTL/HTL push-pull (Vin=Vout), 6 channels, electrically isolated																			G
5000 ppr TTL (RS422), 6 channels																			H
4096 ppr TTL/HTL push-pull (Vin=Vout), 6 channels, electrically isolated																			K
4096 ppr TTL (RS422), 6 channels																			J
3072 ppr TTL/HTL push-pull (Vin=Vout), 6 channels, electrically isolated																			7
3072 ppr TTL (RS422), 6 channels																			8
2048 ppr TTL/HTL push-pull (Vin=Vout), 6 channels, electrically isolated																			9
2048 ppr TTL (RS422), 6 channels																			4
1024 ppr TTL/HTL push-pull (Vin=Vout), 6 channels, electrically isolated																			5
1024 ppr TTL (RS422), 6 channels																			6
512 ppr TTL/HTL push-pull (Vin=Vout), 6 channels, electrically isolated																			1
512 ppr TTL (RS422), 6 channels																			2
Operating temperature																			
-40...+85 °C																			A
-40...+95 °C																			G

(1) Please specify the exact switching speed in addition to the part number (factory setting).

It may happen that not all variants of the type code can be combined. Any restrictions can be found in the web configurator at www.baumer.com or on request.

Accessories

Mounting accessories

11043628	Torque arm M6, length 67...70 mm
11002915	Torque arm M6, length 425...460 mm (≥131 mm)
11054917	Torque arm M6 insulated, length 67...70 mm
11072795	Torque arm M6 insulated, length 120...130 mm (≥71 mm)
11082677	Torque arm M6 insulated, length 425...460 mm (≥131 mm)
11077197	Mounting kit for torque arm size M6 and earthing strap

Connectors and cables

	Sensor cable for encoders HEK 8
	Sensor cable for encoders HEK 17
11068577	Mating connector M23, solder version, 12-pin, CCW
11068551	Mating connector M23, solder version, 17-pin, CCW
11172482	Mating connector M23 (11 pins assigned) 17-pin, CCW with sensor cable HEK 17, length 1 m
11172499	Mating connector M23 (11 pins assigned) 17-pin, CCW with sensor cable HEK 17, length 5 m
11172580	Mating connector M23 (11 pins assigned) 17-pin, CCW with sensor cable HEK 17, length 10 m
11172463	Mating connector M23 (17 pins assigned) 17-pin, CCW with sensor cable HEK 17, length 3 m