

POG 83

Solid shaft $\varnothing 11$ mm with EURO flange B10

512...4096 pulses per revolution

Overview

- Encoder in stainless steel
- Offshore and salt water firm
- Protection IP 66, IP 67 and IP 69K
- Specialy designed for deck machinery and cranes in offshore and marine environment
- M23 flange connector in stainless steel



Technical data

Technical data - electrical ratings

Voltage supply	4.75...30 VDC (HTL/TTL)
Consumption w/o load	≤ 70 mA
Pulses per revolution	512 ... 4096
Phase shift	$90^\circ \pm 10^\circ$
Duty cycle	40...60 %
Reference signal	Zero pulse, width 90°
Sensing method	Optical
Output frequency	≤ 300 kHz (TTL) ≤ 160 kHz (HTL)
Output signals	A+, A-, B+, B-, R+, R-
Output stages	Universal HTL/TTL ($V_{in} = V_{out}$)
Interference immunity	EN 61000-6-2
Emitted interference	EN 61000-6-3
Approval	CE UL approval / E217823

Technical data - mechanical design

Size (flange)	$\varnothing 115$ mm
Shaft type	$\varnothing 11$ mm solid shaft
Admitted shaft load	≤ 250 N axial ≤ 350 N radial

Technical data - mechanical design

Flange	EURO flange B10
Protection EN 60529	IP 66 IP 67 IP 69K
Operating speed	≤ 6000 rpm (mechanical)
Operating torque typ.	6.5 Ncm
Rotor moment of inertia	450 gcm ²
Material	Housing: stainless steel Shaft: stainless steel
Operating temperature	-40...+85 °C
Resistance	IEC 60068-2-6 Vibration 20 g, 10-2000 Hz IEC 60068-2-27 Shock 300 g, 1 ms
Corrosion protection	IEC 60068-2-52 Salt mist for ambient conditions CX (C5-M) according to ISO 12944-2
Connection	Flange connector M23
Weight approx.	3.5 kg

Optional

- Approval DNV GL optional (POG 83 - DNV GL)

POG 83

Solid shaft $\varnothing 11$ mm with EURO flange B10
 512...4096 pulses per revolution

Terminal assignment

View A (see dimension)
 Assignment flange connector

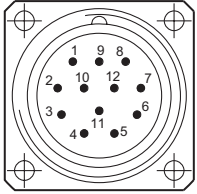

Flange connector M23, male, 12-pin, counter-clockwise (CCW)

Pin	Assignment
1	B-
2	dnu
3	R+
4	R-
5	A+
6	A-
7	dnu
8	B+
9	dnu
10	0V (\perp)
11	dnu
12	+UB

Terminal significance

+UB	Voltage supply
0V (\perp)	Ground
A+	Output signal channel 1
A-	Output signal channel 1 inverted
B+	Output signal channel 2 (offset by 90° to channel 1)
B-	Output signal channel 2 inverted
R+	Zero pulse (reference signal)
R-	Zero pulse inverted
dnu	Do not use

Output signals

HTL/TTL

At positive rotating direction (see dimension)

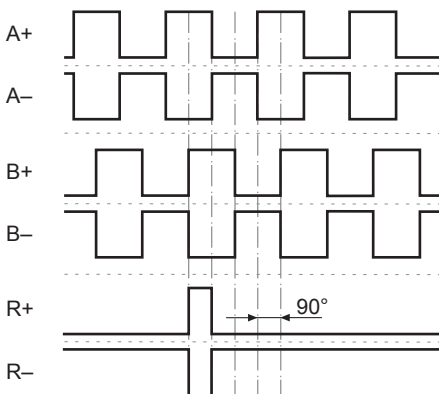

Trigger level

Trigger level	TTL/RS422
High / Low	≥ 2.5 V / ≤ 0.5 V
Load	≤ 20 mA
Trigger level	HTL/push-pull
High / Low	$\geq UB - 3$ V / ≤ 1.5 V
Load	≤ 20 mA

POG 83

Solid shaft $\varnothing 11$ mm with EURO flange B10
512...4096 pulses per revolution

Dimensions

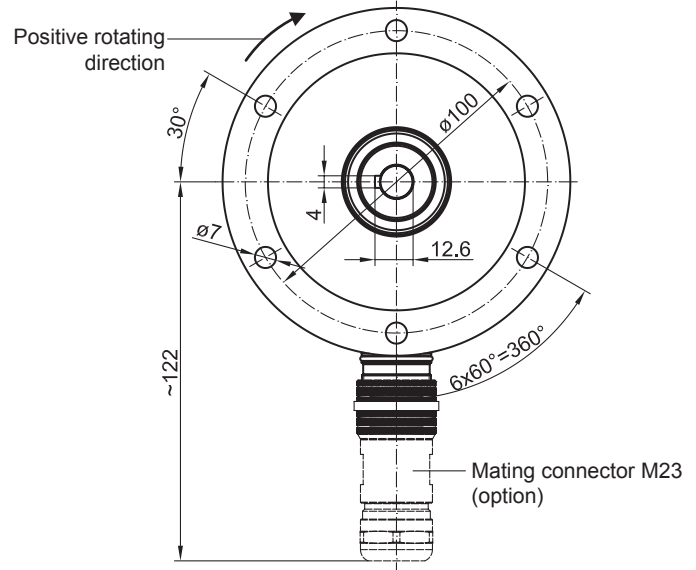
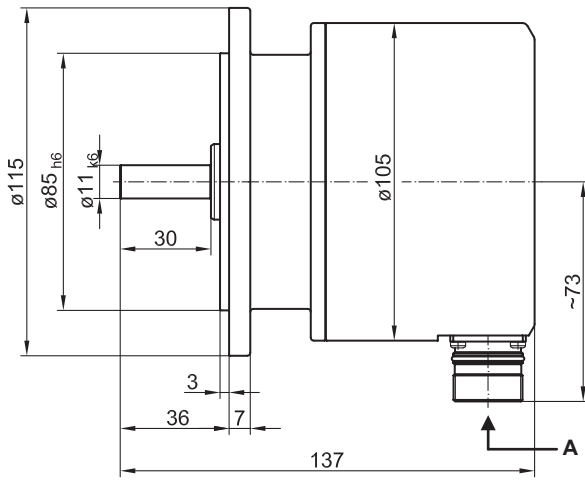

POG 83

Solid shaft \varnothing 11 mm with EURO flange B10
512...4096 pulses per revolution

Ordering reference

	POG83	-	S	N	F	.	1	F	P	.	####
Product	POG83										
Incremental encoder											
Shaft type			S								
Solid shaft											
Flange (Solid shaft)				N							
EURO flange B10, without shaft isolation											
Protection class					F						
IP 66, IP67, IP69K											
Solid shaft							1				
\varnothing 11 mm, featherkey 4 mm											
Connection								F			
Flange connector M23, 12 pin, radial, male contacts, CCW											
Supply voltage / output stages									P		
4,75...30 VDC, HTL/TTL push-pull (Vin=Vout), 6 channels											
Pulses per revolution											
512											0512
1024											1024
2048											2048
4096											4096

(1) Other pulse numbers on request.

Accessories

Mounting accessories

- Spring disk coupling K 35 (shaft \varnothing 6...12 mm)
- Spring disk coupling K 50 (shaft \varnothing 11...16 mm)
- Spring disk coupling K 60 (shaft \varnothing 11...22 mm)