

POG 9

Solid shaft with EURO flange B10
300...5000 pulses per revolution

Overview

- Encoder with solid shaft $\varnothing 11$ mm
- Optical sensing method
- EURO flange B10
- Very high resistance to shock
- Output stage HTL or TTL
- TTL output driver for cable length up to 550 m



Technical data

Technical data - electrical ratings

Voltage supply	9...30 VDC 5 VDC ± 5 %
Consumption w/o load	≤ 100 mA
Pulses per revolution	300 ... 5000
Phase shift	$90^\circ \pm 20^\circ$
Duty cycle	40...60 %
Reference signal	Zero pulse, width 90°
Sensing method	Optical
Output frequency	≤ 120 kHz ≤ 300 kHz (on request)
Output signals	K1, K2, K0 + inverted Error output (option EMS)
Output stages	HTL-P (power linedriver) TTL/RS422
Interference immunity	EN 61000-6-2
Emitted interference	EN 61000-6-3
Approval	CE UL approval / E217823

Technical data - mechanical design

Size (flange)	$\varnothing 115$ mm
Shaft type	$\varnothing 11$ mm solid shaft

Technical data - mechanical design

Admitted shaft load	≤ 250 N axial ≤ 350 N radial
Flange	EURO flange B10
Protection EN 60529	IP 56
Operating speed	≤ 12000 rpm (mechanical)
Operating torque typ.	2 Ncm
Rotor moment of inertia	200 gcm^2
Material	Housing: aluminium die-cast Shaft: stainless steel
Operating temperature	$-30...+100^\circ\text{C}$ $-25...+100^\circ\text{C}$ (>3072 pulses)
Resistance	IEC 60068-2-6 Vibration 10 g, 10-2000 Hz IEC 60068-2-27 Shock 300 g, 1 ms
Corrosion protection	IEC 60068-2-52 Salt mist for ambient conditions C4 according to ISO 12944-2
Explosion protection	II 3 G Ex ec IIC T4 Gc (gas) II 3 D Ex tc IIIB T135°C Dc (dust) (only with option ATEX)
Connection	Terminal box
Weight approx.	1.4 kg

Optional

- Function control with EMS (Enhanced Monitoring System)
- Second shaft end

POG 9

Solid shaft with EURO flange B10
300...5000 pulses per revolution

Terminal assignment

View A (see dimension)

Connecting terminal terminal box

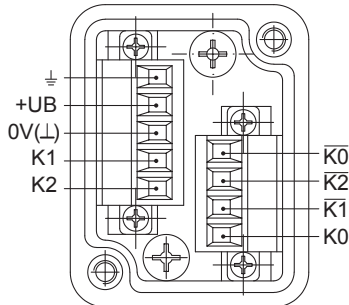

Option EMS: View A (see dimension)

Connecting terminal terminal box

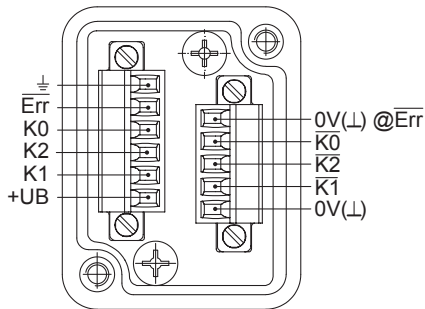

Terminal significance

+UB	Voltage supply
0V (L)	Ground
⊕	Earth ground (housing)
K1	Output signal channel 1
$\bar{K}1$	Output signal channel 1 inverted
K2	Output signal channel 2 (offset by 90° to channel 1)
$\bar{K}2$	Output signal channel 2 inverted
K0	Zero pulse (reference signal)
$\bar{K}0$	Zero pulse inverted
\bar{Err}	Error output (option EMS)

Output signals

HTL/TTL

At positive rotating direction (see dimension)

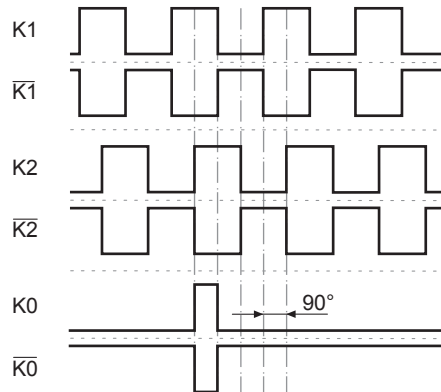

Option EMS: Status LED / error output

Flash light red*	Error of signal sequence, zero pulse or pulses (Error output = HIGH-LOW alternation)
Red	Overload output transistors (Error output = LOW)
Flash light green	Device o.k., rotating (Error output = HIGH)
Green	Device o.k., stopped (Error output = HIGH)
No light	No voltage supply connection or wrong connection (Error output = LOW)

* Only at rotating device

POG 9

Solid shaft with EURO flange B10
300...5000 pulses per revolution

Dimensions

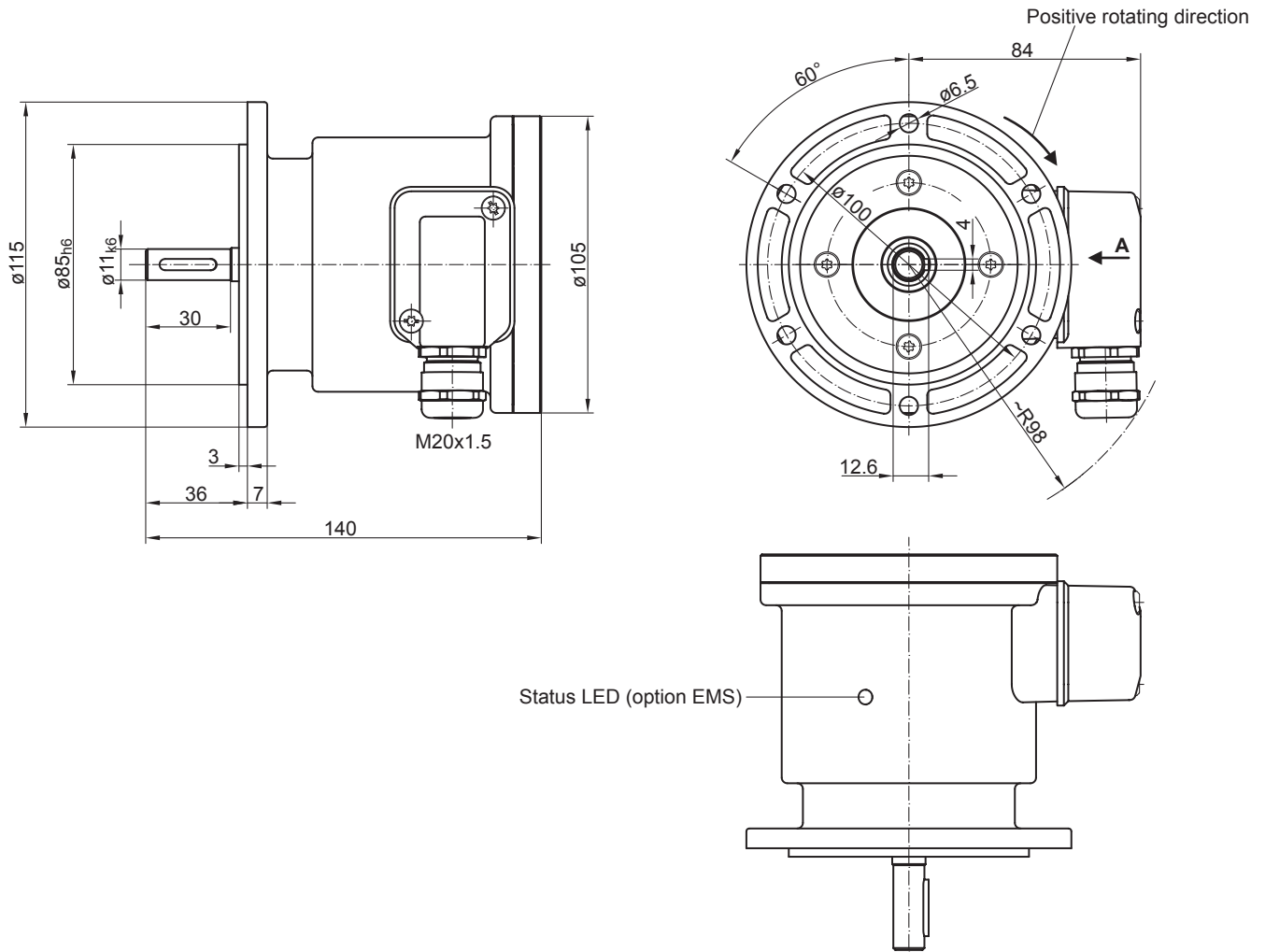

POG 9

Solid shaft with EURO flange B10
300...5000 pulses per revolution

Ordering reference

	POG9	##	DN	####	###
Product	POG9				
Incremental encoder					
EMS - Enhanced Monitoring System					
Without EMS					
With EMS		.2			
Output signals					
K1, K2, K0			DN		
Pulse number⁽¹⁾					
300				300	
500				500	
512				512	
1000				1000	
1024				1024	
1200				1200	
2048				2048	
2500				2500	
3072				3072	
4096				4096	
5000				5000	
Voltage supply / output stage					
9...30 VDC / output stage HTL with inverted signals					I
5 VDC / output stage TTL with inverted signals					TTL
9...30 VDC / output stage TTL with inverted signals					R

(1) Other pulse numbers on request.

Accessories

Mounting accessories

- Spring disk coupling K 35 (shaft ø6...12 mm)
- Spring disk coupling K 50 (shaft ø11...16 mm)
- Spring disk coupling K 60 (shaft ø11...22 mm)